

ASSEMBLY INSTRUCTIONS

Kunz Engineering Inc.

Mendota, IL

AcEASE

Rear Floatation Kit 003910

Front Floatation Kit 003911

2/17



READ THE COMPLETE ASSEMBLY INSTRUCTIONS BEFORE STARTING THE ASSEMBLY.

You should have the following parts with the floatation kit:

- one rear wheel support assembly with clamping flat attached
- one caster support assembly with clamping flat attached



WARNING: Before doing any installations or adjustments shut off mower engine.

FRONT AND REAR FLOATATION KIT INSTALLATION (Refer to Figure 1)

1. Remove the four 1/2" x 3-1/2" bolts, nuts, lock washers and clamping flats from both the caster support and rear wheel support assemblies.
2. Position the rear wheel support and caster support assemblies in the desired location on the cross brace tube. Insert the four 1/2" x 3-1/2" bolts from the bottom up and place the clamping flat on the top. Secure the bolts with the lock washers and the nuts. Tighten down appropriately to prevent unwanted loosening.

Note: If the ATV Tongue was purchased with the mower and the floatation kit is positioned to the same side as the ATV tongue there may be interference. It may be necessary to either move the front floatation kit assembly over slightly or relocate the tongue and hitch pivot to the opposite side.

Note: The recommended location for the floatation kit is to the left of center. If the floatation kit is placed in the center portion of the mower deck, the mower may rock back and forth when mowing on a crowned surface. With the floatation kit positioned to the left of center the mower will also be more stable when mowing around a pond bank or extending the mower deck over an edge.

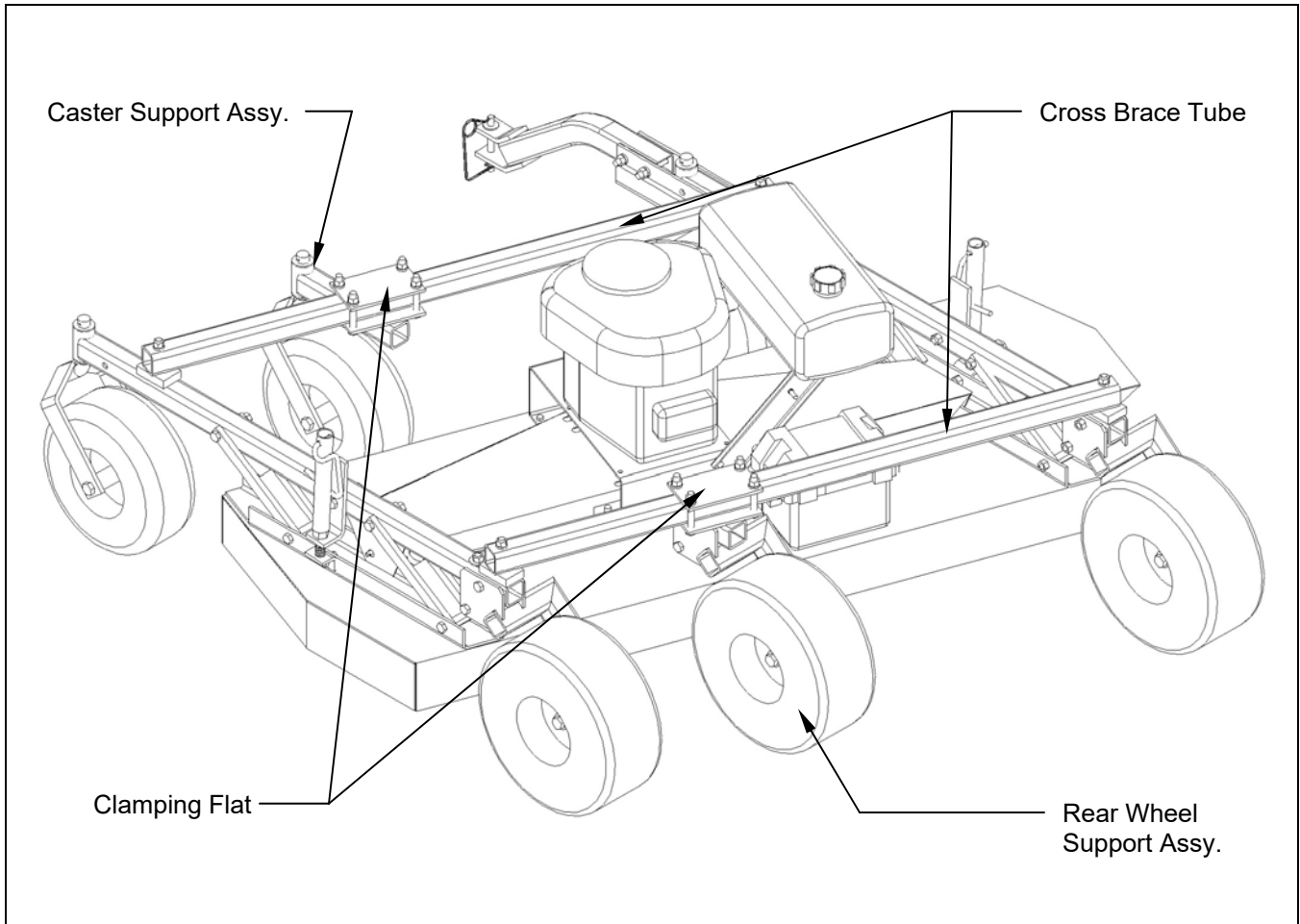
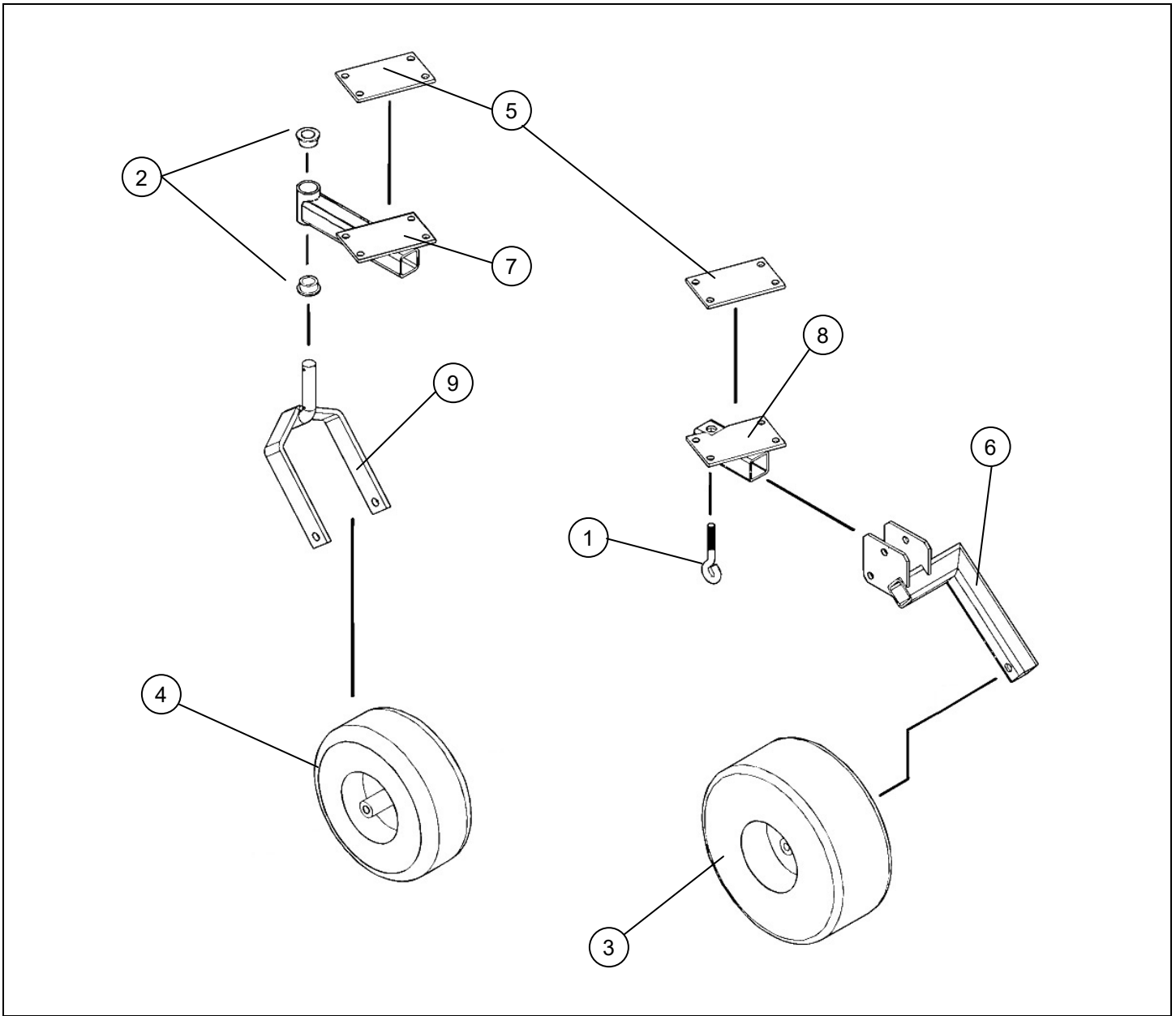

Figure 1: Installation of Floatation Kit Parts



PARTS LIST

<u>Item</u>	<u>Part #</u>	<u>Description</u>	<u>Quantity</u>
1	204015	Eye Bolt (Welded)	1
2	243010	Plastic Bearing (1-3/8" O.D. x 1.00" I.D., Flange, Nylon)	2
3	226012	Offset Wheel Assy., 15/600 x 6, 4 Ply Turf	1
4	226016	Centered Wheel Assy., 13/500 x 6, 4 Ply Slick	1
5	600195	Clamping Flat	2
6	900125	Rear Wheel Support	1
7	900134	Caster Support	1
8	900135	Rear Wheel Mount	1
9	900148	Caster Fork	1
	222012	Single Split Collar (1" I.D. x .1/2" Thick)	1