

# ASSEMBLY INSTRUCTIONS

**AcEASE**

Kunz Engineering Inc.

Mendota, IL

Rear Floatation Kit 003907

Front Floatation Kit 003908

Cross Brace Tube Assy. 900113

12/20



## READ THE COMPLETE ASSEMBLY INSTRUCTIONS BEFORE STARTING THE ASSEMBLY.

### You should have the following parts with the complete floatation kit:

- one rear wheel support assembly with receiver assembly and clamping flat attached
- one caster support assembly with receiver assembly and clamping flat attached
- two cross brace tube assemblies

### You should have the following parts if you currently have an electric lift kit or a 44" model:

- one rear wheel support assembly with receiver assembly and clamping flat attached
- one caster support assembly with receiver assembly and clamping flat attached
- four 1/2" thick spacer flats (44" rough cut models only)



**WARNING** Before doing any installations or adjustments shut off mower engine.

### A. CARRIER ARM PREPARATION (Refer to Figure 1)

1. For models that already have mounting holes present, section A. can be omitted. For models with the electric lift kit installed or any 44" rough cut models, refer to section E. For models without mounting holes, locate the hole positioning according to figure 1. The measurement should be taken from the front edge of the carrier arm and extend to the center of each hole. The front hole should be at a distance of 10-3/4" from the front edge of the carrier arm and the rear hole should be 65-9/16" from the front edge of the carrier arm. Hole positioning will need to be located on both the left and right carrier arms.
2. Using a 17/32" (.531") drill bit, drill all four holes. Take care to drill straight through the carrier arms.

**Note:** Hole misalignment from top to bottom may cause difficulty during assembly.

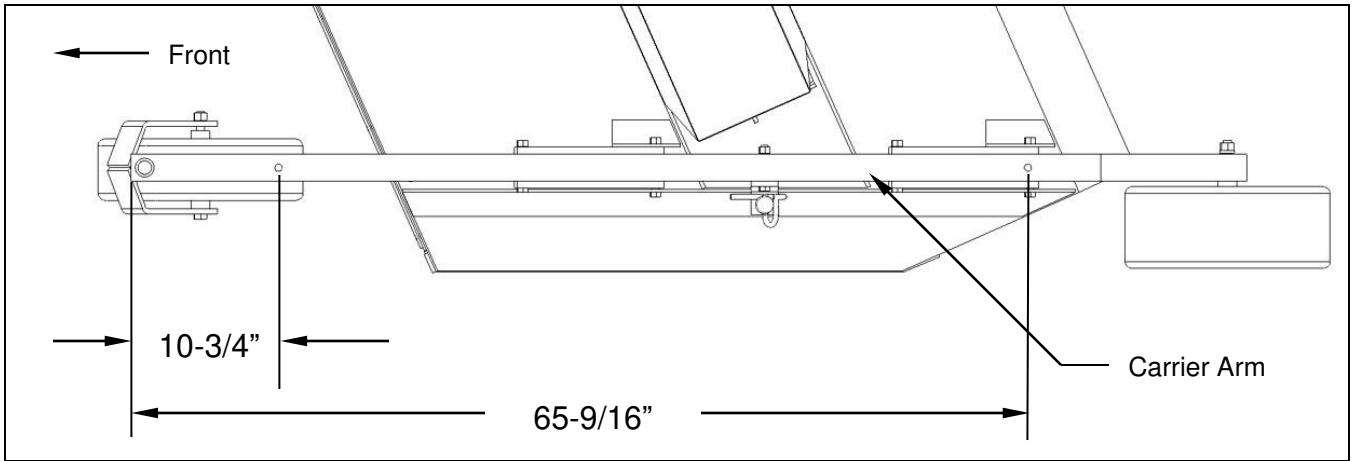

Figure 1. Carrier Arm Hole Location

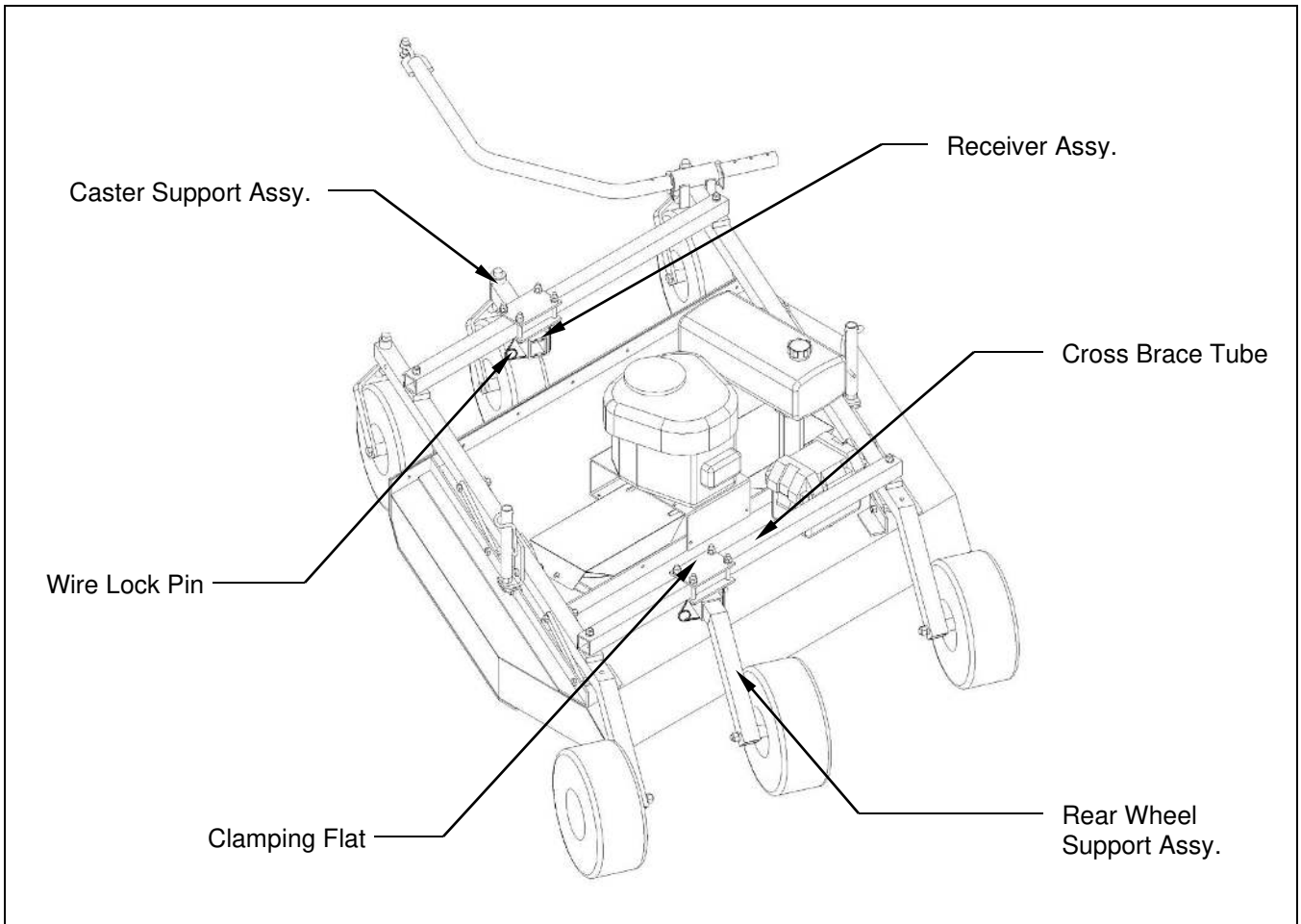

Figure 2. Assembly of Floatation Kit Parts

## **B. INSTALL CROSS BRACE TUBES (Refer to Figure 2)**

1. Remove the 1/2" x 5-1/2" bolts and lock nuts from the ends of both of the cross brace tubes and save for step 2.
2. Align the cross brace tubes over the holes that were drilled in section A. For models that already have mounting holes present, use the two holes that are closest to the center of the carrier arm. Place the 1/2" x 5-1/2" bolts through the carrier arm from the bottom up. Place the lock nut on the bolt from the top side. Snug the lock nut up but do not fully tighten. The cross brace tube needs to pivot slightly during height adjustment.

## **C. INSTALL RECEIVER ASSEMBLIES AND CLAMPING FLATS (Refer to Figure 2)**

1. Remove the wire lock pin from both of the receiver assemblies and save for section D.
2. Remove the caster support assembly and rear wheel support assembly from the receiver assemblies.
3. Remove the four 1/2" x 3-1/2" bolts, nuts and lock washers from each receiver assembly and clamping flat.
4. Position the receiver assemblies in the desired location on the cross brace tube. Insert the four 1/2" x 3-1/2" bolts from the bottom up and place the clamping flat on the top. Secure the bolts with the lock washer and the nut. Tighten down appropriately to prevent unwanted loosening.

**Note:** If the floatation kit is positioned to the same side as the tongue there may be interference. It may be necessary to relocate the tongue and hitch pivot to the opposite side.

## **D. INSTALL CASTER SUPPORT ASSY. AND REAR WHEEL SUPPORT ASSY. (Refer to Figure 2)**

1. Insert the caster support assembly into the front receiver assembly and install the wire lock pin.
2. Insert the rear wheel support assembly into the rear receiver assembly and install the wire lock pin.

## **E. INSTALLATION OF FLOTATION KIT PARTS ON ELECTRIC LIFT KIT MODELS AND 44" ROUGH CUT MODELS (Refer to Figure 3)**

1. Remove the wire lock pin from both of the receiver assemblies and save for step 5 and 6.
2. Remove the caster support assembly and rear wheel support assembly from the receiver assemblies.
3. Remove the four 1/2" x 3-1/2" bolts, nuts and lock washers from each receiver assembly and clamping flat.

**Note:** On the 44" models there are four 1/2" thick spacer plates provided. Position these plates between the carrier arms and the upper actuator mounts (also known as cross brace tubes) as shown in Figure 3.

4. Position the receiver assemblies in the desired location on the upper actuator mount. Insert the four 1/2" x 3-1/2" bolts from the bottom up and place the clamping flat on the top. Secure the bolts with the lock washer and the nut. Tighten down appropriately to prevent unwanted loosening.

**Note:** If the floatation kit is positioned to the same side as the tongue there may be interference. It may be necessary to relocate the tongue and hitch pivot to the opposite side.

5. Insert the caster support assembly into the front receiver assembly and install the wire lock pin.
6. Insert the rear wheel support assembly into the rear receiver assembly and install the wire lock pin.

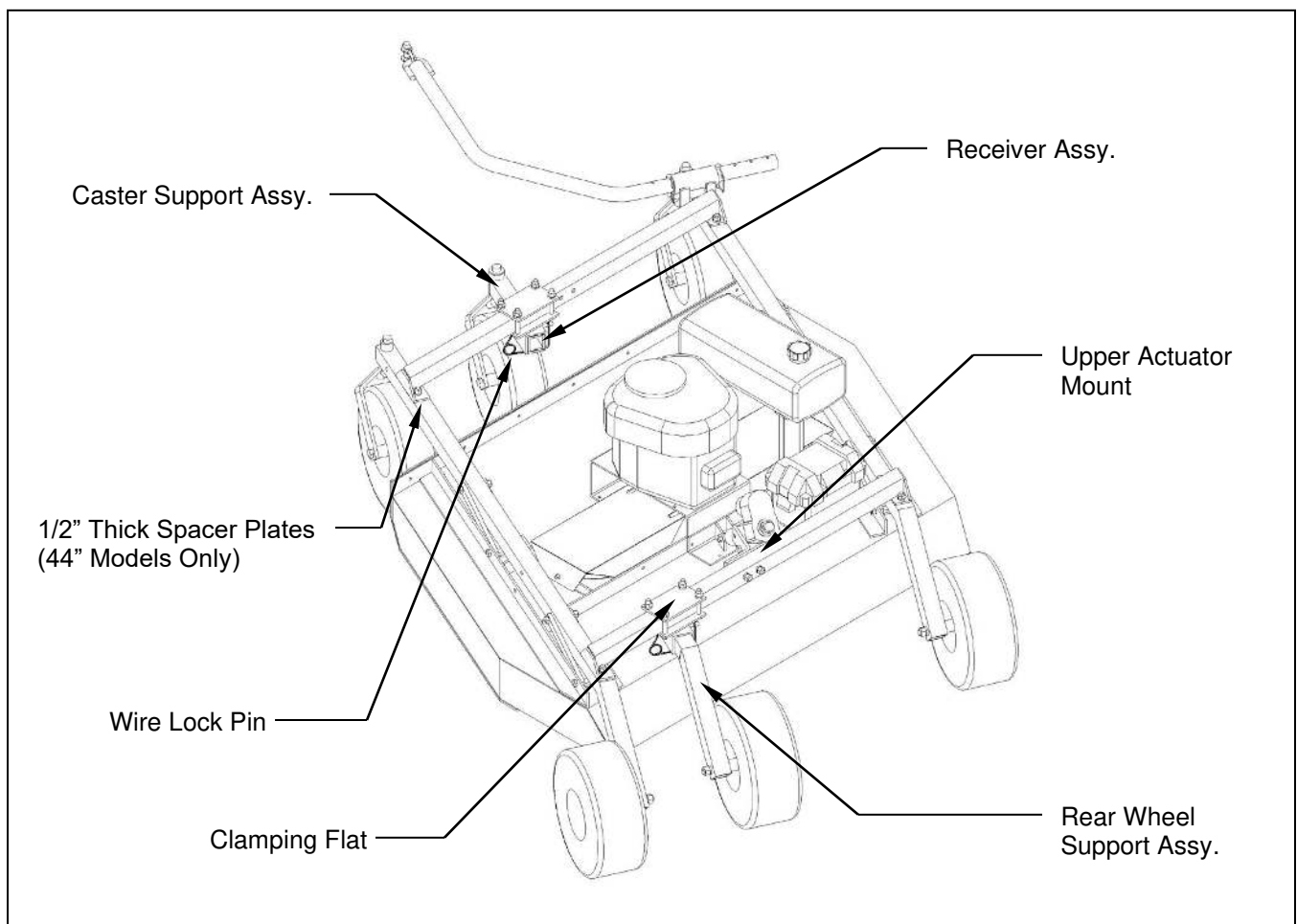
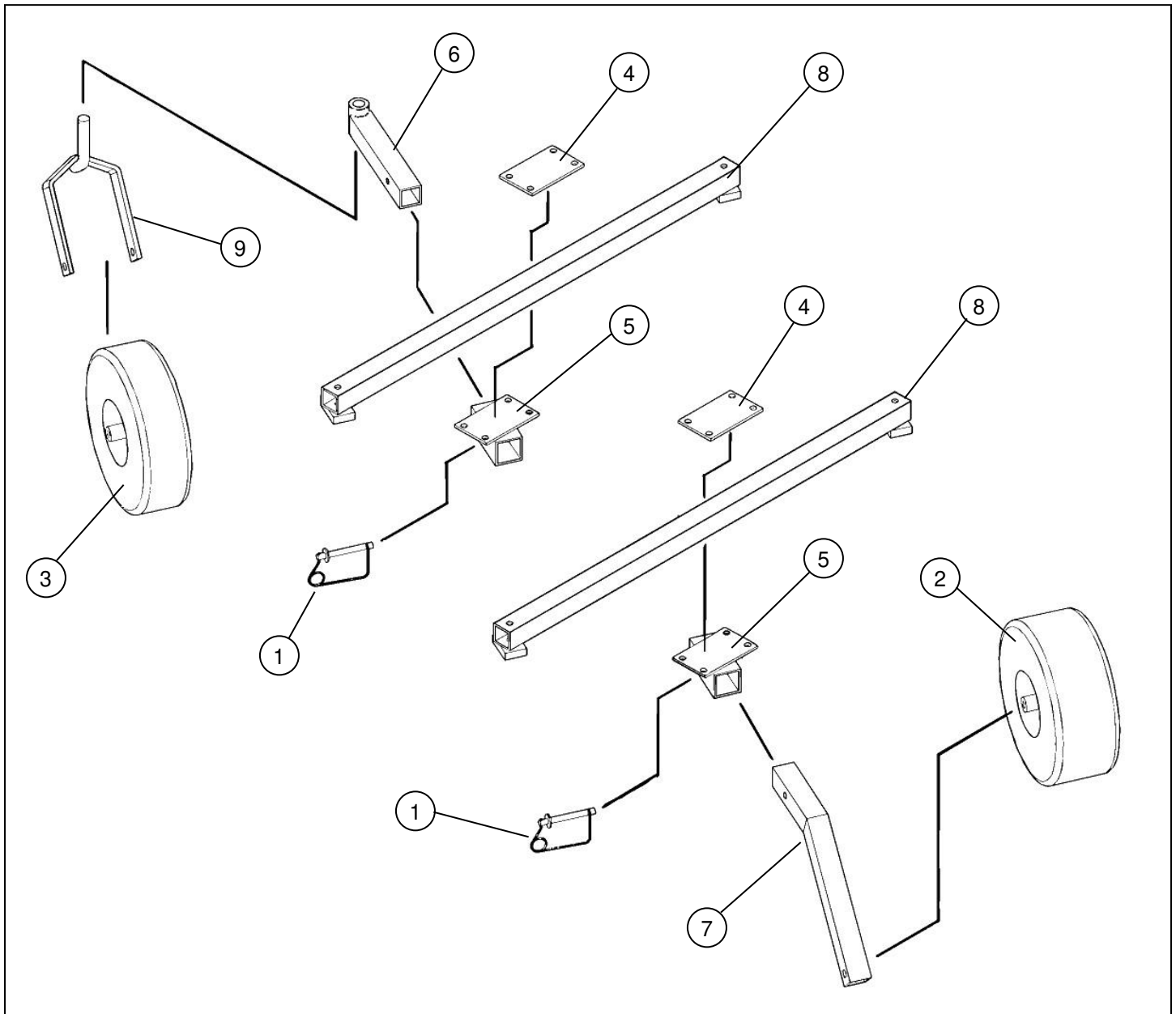

Figure 3. Assembly of Floatation Kit Parts on Electric Lift Kit Models & 44" Models



### PARTS LIST

<u>Item</u>	<u>Part #</u>	<u>Description</u>	<u>Quantity</u>
1	216011	Wire Lock Pin (1/2" x 3-1/2" Opening)	2
2	226012	Offset Wheel Assy. (15/60 x 6, 4 Ply Turf)	1
3	226013	Centered Wheel Assy. (5.30/4.50 x 6, 4 Ply Stud)	1
4	600195	Clamping Flat	2
5	900107	Receiver Assy.	2
6	900108	Caster Support	1
	243010	Plastic Bearing (1-3/8" O.D. x 1.00" I.D., Flange, Nylon)	2
7	900109	Rear Wheel Support	1
8	900110	Cross Brace Tube	2
9	900148	Caster Fork	1
	222012	Single Split Collar (1" I.D. x .1/2" Thick)	1
	600272	Spacer Flat (1/2" Thick) (44" Models Only - Not Shown In Diagram)	4