

# ASSEMBLY INSTRUCTIONS

**Till-Ease**

Kunz Engineering Inc.

Mendota, IL

Drag Harrow Part # 003800 (48" Version)  
& 003804 (66" Version)

## READ THE COMPLETE ASSEMBLY INSTRUCTIONS BEFORE STARTING THE ASSEMBLY.

You should have the following parts with the complete kit:

- one drag harrow assembly

### A. DRAG HARROW PREPARATION – Refer to Figure 1.

1. Unhook the snap hook from the eye bolts on both sides of the drag harrow.
2. Rotate the support tubes 180 degrees away from the drag harrow.
3. Rotate the loose end of the free tow links 180 degrees away from the drag harrow.
4. Remove the unused  $3/8"$  x  $2-1/4"$  bolt and nylon insert lock nut from each support tube.
5. Position the hole on the free end of the tow links with the hole location on the support tube where the bolt was removed in the previous step.
6. Insert the  $3/8"$  x  $2-1/4"$  bolt through the aligned holes and fasten with the nylon insert lock nut. This location is a pivot point and should not be fully tightened.
7. Hook the snap hooks on the appropriate eye bolts.

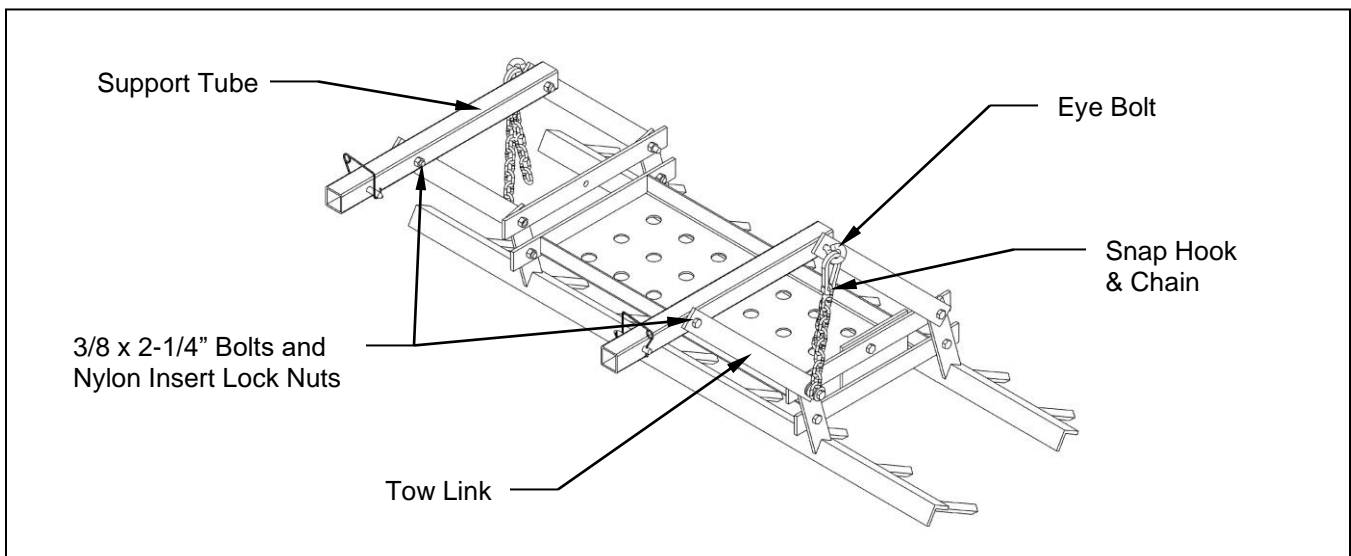

Figure 1. Drag Harrow Assembly

### B. INSTALLING ON TILLAGE TOOL – Refer to Figure 2.

1. Remove the provided wire lock pins from each support tube.
2. Align the support tubes with the attachment receivers on the tillage tool and insert.
3. Insert and securely fasten the wire lock pins through the attachment receivers.

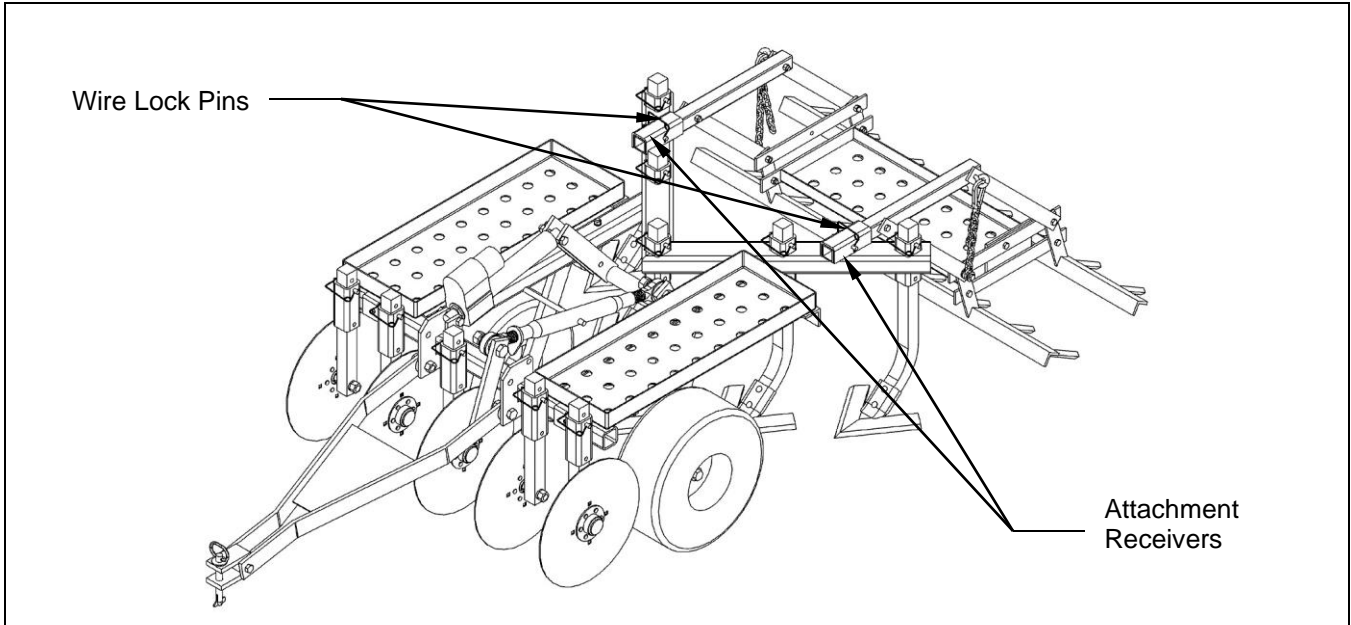

Figure 2. – Drag Harrow Installation

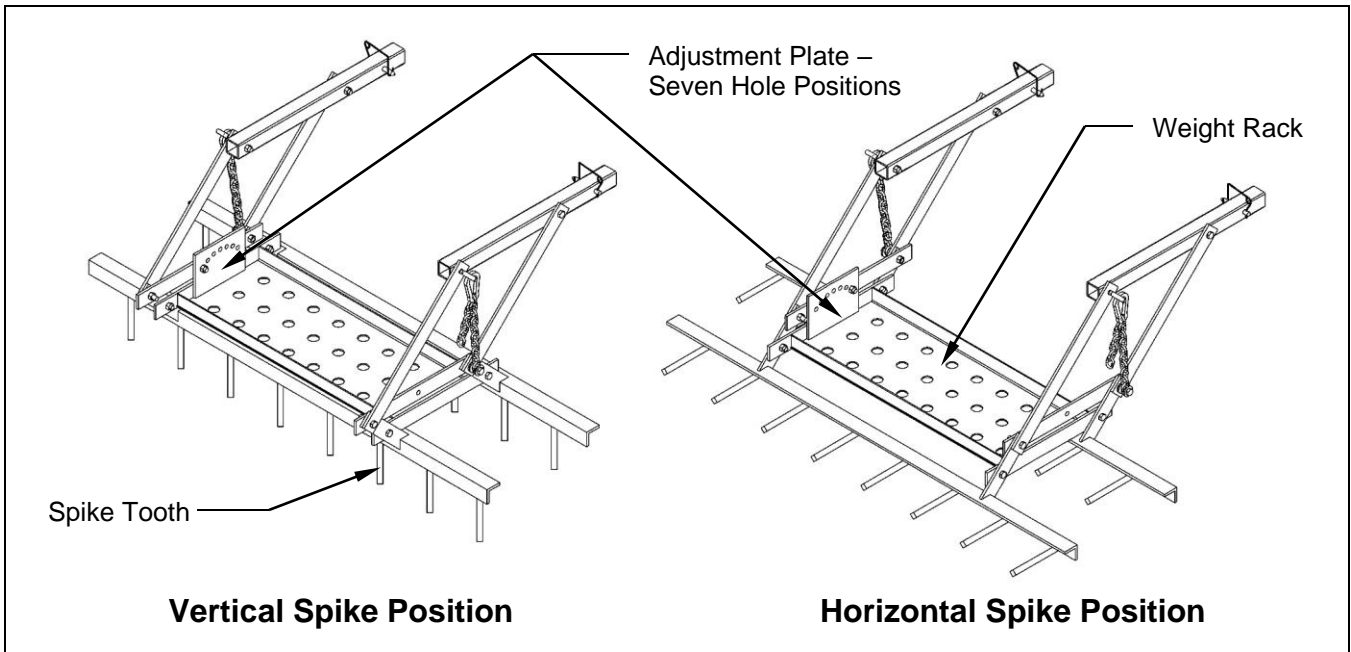

Figure 3. – Spike Tooth Positioning

### C. ADJUSTING FOR USE

There are two separate adjustments that can be made on this drag harrow for various applications and conditions.

The drag harrow can be adjusted up and down by readjusting the chain and snap hook position. This allows the operator to adjust the down pressure for different soil types or tillage depths. The drag harrow also has the ability to contact the ground with the sweeps and coulters fully removed from the ground.

**Note:** If additional pressure is desired, weight can be added to the weight rack on the drag harrow.

The second adjustment that can be made to the drag harrow is the spike tooth angle. There are seven different hole positions which result in spike tooth positioning from vertical to horizontal. **(See Figure 3.)**

# PARTS LIST

<u>Item</u>	<u>Part #</u>	<u>Description</u>	<u>003800 Qty.</u>	<u>003804 Qty.</u>
1	216013	Wire Lock Pin	2	2
2	222011	Safety Snap Hook	2	2
3	500025	Tow Link	4	4
4	500026	Support Tube	2	0
4	500066	Support Tube	0	2
5	500027	Upper Link Flat	2	2
6	800004	Front Harrow Section	1	0
6	800025	Front Harrow Section	0	1
7	800005	Rear Harrow Section	1	0
7	800026	Rear Harrow Section	0	1
8	800009	Harrow Frame	1	1

## DRAG HARROW PARTS

